

ATTO D4 DC

INSTALLATION INSTRUCTIONS

COPYRIGHT

Electrex is a trademark of Akse S.r.l. All rights reserved.

It is forbidden to duplicate, adapt, transcript this document without Akse written authorization, except when regulated accordingly by the Copyright Laws.

WARRANTY

This product is covered by a warranty against material and manufacturing defects for a 24 months period from the manufacturing date.

The warranty does not cover the defects that are due to:

- Negligent and improper use
- Failures caused by atmospheric hazards
- Acts of vandalism
- Wear out of materials
- Firmware upgrades

Akse reserves the right, at its discretion, to repair or substitute the faulty products

The warranty is not applicable to the products that will result defective in consequence of a negligent and improper use or an operating procedure not contemplated in this manual.

RETURN AND REPAIR FORMALITIES

Akse accepts the return of instruments for repair only when authorized in advance. The transport costs are at customer charge.

RE-SHIPING OF REPAIRED PRODUCT

The terms for re-shipment of repaired products are ex-works, i.e. the transport costs are at customer charge.

Products returned as defective but found to be perfectly working by our laboratories, will be charged a flat fee to account for checking and testing time irrespective of the warranty terms.

SAFETY

This instrument was manufactured and tested in compliance with IEC 61010-1 CAT III-300V class 2 standards for exercise voltages up to 300 Vac rms phase to neutral.

In order to maintain this condition and to ensure safe operation, the user must comply with the indications and markings contained in the following instructions:

- When the instrument is received, before starting its installation, check that it is intact and no damage occurred during transport.
- Before mounting, ensure that the instrument operating voltages and the mains voltage are compatible then proceed with the installation.
- The instrument power supply needs no earth connection.
- The instrument is not equipped with a power supply fuse; a suitable external protection fuse must be foreseen by the contractor.
- Maintenance and/or repair must be carried out only by qualified, authorized personnel
- If there is ever the suspicion that safe operation is no longer possible, the instrument must be taken out of service and precautions taken against its accidental use.
- Operation is no longer safe when:

- 1) There is clearly visible damage.
- 2) The instrument no longer functions.
- 3) After lengthy storage in unfavorable conditions.
- 4) After serious damage occurred during transport

The instruments must be installed in respect of all the local regulations.

OPERATOR SAFETY

Warning: Failure to observe the following instructions may lead to a serious danger of death.

- During normal operation dangerous voltages can occur on instrument terminals and on voltage and current transformers. Energized voltage and current transformers may generate lethal voltages. Follow carefully the standard safety precautions while carrying out any installation or service operation.
- The terminals of the instrument must not be accessible by the user after the installation. The user should only be allowed to access the instrument front panel where the display is located.
- Do not use the digital outputs for protection functions nor for power limitation functions. The instrument is suitable only for secondary protection functions.
- The instrument must be protected by a breaking device capable of interrupting both the power supply and the measurement terminals. It must be easily reachable by the operator and well identified as instrument cut-off device.
- The instrument and its connections must be carefully protected against short-circuit.

Precautions: Failure to respect the following instructions may irreversibly damage to the instrument.

- The instrument is equipped with PTC current limiting device but a suitable external protection fuse should be foreseen by the contractor.
- The outputs and the options operate at low voltage level; they cannot be powered by any unspecified external voltage.
- The application of currents not compatible with the current inputs levels will damage to the instrument.

Further documentation may be downloaded from our web site www.electrex.it.

This document is owned by the company AKSE that reserves all rights.

DECLARATION OF CONFORMITY

Akse hereby declares that its range of products complies with the following directives EMC 89/336/EEC 73/23CE 93/68 CE and complies with the following product's standard CEI EN 61326 – IEC 61326 CEI EN 61010 – IEC 61010.

The product has been tested in the typical wiring configuration and with peripherals conforming to the EMC directive and the LV directive.

Subject to modification without notice. Edition 06-10-2010

The instrument will be distributed with the following default configuration

PAGE	MENU DISPLAYED	AVAILABLE PARAMETERS	DEFAULT
PASSWORD		0000 ... 9999	0000
RS485			
	RS 485 ADDRESS	1 ... 247	27
	Comm. Speed	2400, 4800, 9600, 19200, 38400	38400
	Data Bit	7 o 8	8
	Parity	N = no parity, E = parity equal, O = parity unequal	N
	Bit of stop	1 o 2	2
NETWORK			
	Export	NO, YES	NO
	I FS	1 ... 10000	00010
	SHUNT	60 or 100	60
	VR	400000/999	1/1
AVG-MD TIME (note n.2)			
	POWERS	1...60 (minutes)	15
	CURRENTS	1...60 (minutes)	8
ALARM 1 / A (note n.11)			
	MODE (note n.3)	Normal, DERIV	NORMAL
	TYPE (note n.4)	MAX, MIN	MIN
	MEAS (note n.5)	Controlled measure. See table n.1 for the register selection.	200
	THRE (note n.5)	Threshold value.	0
ALARM 1 / B			
	HYST	1...100 (%)	1
	DELAY	1...99 (seconds)	1
	AVG (note n.6)	1...99 (seconds)	1
	OUT (note n.7)	Normal, Hold, Pulse-L, Pulse-S	NORMAL
ALARM 2 / A (note n.11)			
	MODE (note n.3)	Normal, DERIV	NORMAL
	TYPE (note n.4)	MAX, MIN	MIN
	MEAS (note n.5)	Controlled measure. See table n.1 for the register selection.	200
	THRE (note n.5)	Threshold value.	0
ALARM 2 / B			
	HYST	1...100 (%)	1
	DELAY	1...99 (seconds)	1
	AVG (note n.6)	1...99 (seconds)	1
	OUT (note n.7)	Normal, Hold, Pulse-L, Pulse-S	NORMAL
ALARM 3 / A (note n.11)			
	MODE (note n.3)	Normal, DERIV	NORMAL
	TYPE (note n.4)	MAX, MIN	MIN
	MEAS (note n.5)	Controlled measure. See table n.1 for the register selection.	200
	THRE (note n.5)	Threshold value.	0
ALARM 3 / B			
	HYST	1...100 (%)	1
	DELAY	1...99 (seconds)	1
	AVG (note n.6)	1...99 (seconds)	1
	OUT (note n.7)	Normal, Hold, Pulse-L, Pulse-S	NORMAL
ALARM 4 / A (note n.11)			
	MODE (note n.3)	Normal, DERIV	NORMAL
	TYPE (note n.4)	MAX, MIN	MIN
	MEAS (note n.5)	Controlled measure. See table n.1 for the register selection.	200
	THRE (note n.5)	Threshold value.	0
ALARM 4 / B			
	HYST	Normal, DERIV	1
	DELAY	MAX, MIN	1
	AVG (note n.6)	Controlled measure. See table n.1 for the register selection.	1
	OUT (note n.7)	Threshold value.	NORMAL
DIGITAL OUT 1 (note n.8)			
	MODE	PULSE, ALARM, REMOTE	PULSE
	POLARITY	NO, NC	NO
PULSE OUT 1			
	MEAS (note n.9)	P-IMP, P-EXP	P-IMP
	PRIMARY (note n.10)	YES, NO	YES
	WEIGHT	1...100000000 (Wh/100)	100000
	WIDTH	50ms...1S	500
DIGITAL OUT 2 (note n.8)			
	MODE	PULSE, ALARM, REMOTE	PULSE
	POLARITY	NO, NC	NO
PULSE OUT 2			
	MEAS (note n.9)	P-IMP, P-EXP	P-EXP
	PRIMARY (note n.10)	YES, NO	YES
	WEIGHT	1...100000000 (Wh/100)	100000
	WIDTH	50ms...1S	500

MECHANICAL CHARACTERISTICS	
Enclosure	Self-extinguishing plastic material class V0
Protection degree	IP40 on front panel
Dimensions	70 x 90 x 58 mm (4 DIN modules)
VOLTAGE INPUT	
Direct	Up to 300 V
	max 360 V
Power supply	230/240Vac +/- 10% 50/60Hz
Self consumption	< 3VA
MODELS	
PFA7471-02	ATTO D4 DC RS485 230-240V ENERGY ANALYSER
PFA7471-12	ATTO D4 DC RS485 230-240V 1DI 2DO ENERGY ANALYSER

Holding Registers			
Address	n° Register	Type	Description
100	2	I	Primary - Voltage Divider
102	1	I	Secondary - Voltage Divider
103	1	I	Bottom Scale - Shunt
104	1	I	Output - Shunt
105	1	B	Insertion mode
106	1	I	Integration Time for Power
107	1	I	Integration Time for Current
109	1	B	Life Timer 2 (partial)
110	1	B	Energy Counters set 1 (totals)
111	1	B	Energy Counters set 2 (partials)
112	2	F	Multiplier CNT1
120	2	I	Measure unit CNT1
128	1	I	Total counters set symbol
129	1	I	Partial counters set symbol
135	1	I	Pulse output 1 measure selection
136	1	I	Pulse length output 1
137	2	I	Pulse weight output 1
139	1	I	Pulse output 2 measure selection
140	1	I	Pulse length output 2
141	2	I	Pulse weight output 2
151	1	B	Configuration DI 1
155	1	B	Configuration DO 1
156	1	B	Configuration DO 2
159	1	I	Type of measure selection on alarm 1
160	1	I	Mode alarm 1
161	1	I	Logic combination alarm 1
162	1	I	Integration time alarm 1
163	1	I	Hysteresis alarm 1
164	1	I	Delay alarm 1
165	2	F	Threshold alarm 1
167	1	I	Type of measure selection on alarm 2
168	1	I	Mode alarm 2
169	1	I	Logic combination alarm 2
170	1	I	Integration time alarm 2
171	1	I	Hysteresis alarm 2
172	1	I	Delay alarm 2
173	2	F	Threshold alarm 2
215	1	I	Serial port transmission delay

216	1	B	Serial port: flags of swap	Byte alto sempre uguale a byte basso. 0x01 Swap bytes 0x02 Swap word 0x04 Swap dwords 0x08 Swap words in floats 0x10 Swap bytes in floats 0x80 BCD Mode (not yet!)
217	1	I	Serial port: speed	0=2400, 1=4800, 2=9600, 3=19200, 4=38400
221	1	B	Digital Output command	Bit 0 = Output 1, Bit 1 = Output 2 Bit 2 = Output 3, Bit 3 = Output 4
223	1	B	Combined Alarm Status	Bit 0 = Channel 1, Bit 1 = Channel 2 Bit 2 = Channel 3, Bit 3 = Channel 4
226	1	I	Instrument Reset	Writing of the word "0xDEAD" will cause the restart
230	1	B	Reset Counters set 1 (total)	Bit 0 = Ea Imp, Bit 4 = Ea Exp, Bit 8 = CNT1
231	1	B	Reset Counters set 2 (partial)	Bit 0 = Ea Imp, Bit 4 = Ea Exp, Bit 8 = CNT1
235	1	B	Set to zero AVG powers	Bit 0 = P Imp, Bit 4 = P Exp
236	1	B	Set to zero MD powers	Bit 0 = P Imp, Bit 4 = P Exp
237	1	B	Set to zero AVG currents	Bit 0 = I1
238	1	B	Set to zero MD currents	Bit 0 = I1
239	1	B	Set to zero min/max Us	Bit 0 = max U1, Bit 4 = min U1
240	1	B	Set to zero min/max Ud	Bit 0 = max U1, Bit 4 = min U1
241	1	B	Set to zero min/max I	Bit 0 = max I1
242	1	B	Set to zero min/max Pimp	Bit 0 = max P1
243	1	B	Set to zero min/max Pexp	Bit 0 = max P1

F	Float IEEE754
I	Integer
B	Bitmapped

INPUT REGISTERS					
Address	n° Register	Type	Description	Symbol	Unit
220	2	F	Phase to Neutral Voltage, RMS Amplitude	U1N	[V]
232	2	F	Phase Current, RMS Amplitude	I1	[A]
240	2	F	Phase Active Power (+/-)	P1	[W]
284	2	F	Temperature, °C	T	[°C]
286	2	F	Temperature, °F	T	[°F]
288	2	F	Phase to Neutral Voltage, RMS Amplitude, MIN	U1N MIN	[A]
294	2	F	Phase to Neutral Voltage, RMS Amplitude, MAX	U1N MAX	[A]
312	2	F	Phase Current, RMS Amplitude, MAX	I1 MAX	[A]
320	2	F	Phase Active Power, Import, MAX	P1+ MAX	[A]
326	2	F	Phase Active Power, Export, MAX	P1- MAX	[A]
332	2	F	Phase Current, RMS Amplitude, AVG	I1 AVG	[A]
338	2	F	Phase Current, RMS Amplitude, MD	I1 MD	[A]
344	2	F	Total imported active power, AVG	P+ AVG	[W]
352	2	F	Total exported active power, AVG	P- AVG	[W]
360	2	F	Total imported active power, MD	P+ MD	[W]
368	2	F	Total exported active power, MD	P- MD	[W]
376	2	F	External Pulse Counter, With Weight, Total counter or Tariff T1	CNT1 S	
384	2	F	External Pulse Counter, With Weight, Partial Counter or Tariff T2	CNT1 P	
392	2	I	External Pulse Counter, Total counter or Tariff T1	CNT1 S	[-]
400	2	I	Lifetimer, Total counter	TIME S	[s]
402	2	I	External Pulse Counter, Partial Counter or Tariff T2	CNT1 P	[-]
410	2	I	Lifetimer, Partial Counter or Conditional Counter	TIME P	[s]
428	2	I	Total imported active energy, Partial Counter or Tariff T2	Ea P +	[kWh/10]
436	2	I	Total exported active energy, Partial Counter or Tariff T2	Ea P -	[kWh/10]
492	1	B	Digital Inputs Status	DI	[-]
494	1	B	Alarms Status (simple)	ALS	[-]
495	1	B	Alarms Status (combined)	ALC	[-]
528	4	I	Total imported active energy, Partial Counter or Tariff T2	Ea P +	[Wh/10]
544	4	I	Total exported active energy, Partial Counter or Tariff T2	Ea P -	[Wh/10]

NOTE n.2	
POWERS	Integration time of the average value (AVG) and max. value (MD) for power (from 1 to 60 minutes)
CURRENTS	Integration time of the average value (AVG) and max. value (MD) for power (from 1 to 60 minutes)
NOTE n.3	
NORMAL	Classic alarm with reference to a fixed or max / min threshold, with applicable hysteresis and delay. The "AVG" parameter is not used.
DERIV	The "THRE" parameter becomes a percentage value. The instantaneous value applied to the alarm on "MEAS" will be compared with its averaged value obtained depending on the time set on "AVG". When the instantaneous value combined to the alarm differs in "more then" (if set "MAX") or in "less then" (if set "MIN") compared to the average value ("AVG") of the percentage set on "THRE", the alarm triggers. With applicable hysteresis and delay. The "AVG" parameter is used.
NOTE n.4	
MAX	Alarm configuration in "excess" according to the conditions set.
MIN	Alarm configuration in "excess" according to the conditions set.
NOTE n.5	
MEAS	Indicates on which register (and on which measure) the alarm is reported. See table n.1 (Input Register).
THRE	Alarm threshold in absolute value, except the "DERIV" value where the value inserted becomes a percentage.
NOTE n.6	
AVG	Parameter to be used in the sole "DERIV" mode. Floating window amplitude (in seconds) used for creating a reference value to which compare the instantaneous value.
NOTE n.7	
NORMAL	The output remains exited during all the alarm, after all it falls.
HOLD	The output remains exited until the manual reset made through Modbus
PULSE-L	The output generates a 500ms pulse on the alarm triggering.
PULSE-S	The output generates a 100ms pulse on the alarm triggering.
NOTE n.8	
PULSE	Enables output function as impulsive
ALARM	Enables output function as alarm
REMOTE	Enables output function through Modbus Protocol
NO	Normally open
NC	Normally closed
NOTE n.9	
P-IMP	Imported Active Power (Energy)
P-EXP	Exported Active Power (Energy)
NOTE n.10	
YES	Referred to the primary of the CT
NO	Referred to the secondary of the CT
NOTE n.11	
ALARM 1	Alarm associated to the physic output DIGITAL OUT 1 (DO1, terminal 8)
ALARM 2	Alarm associated to the physic output DIGITAL OUT 2 (DO2, terminal 9)
ALARM 3	MODBUS only alarm
ALARM 4	MODBUS only alarm

ALARM SETTING EXAMPLES

In order that the output "DIGITAL OUT 1" gets excited and remains such during all the alarm (latching): when the Average Active Power (MEAS 344) exceeds the value of 100 kW, hysteresis 5% and delay of 5 seconds, set the parameters as in the table below:

ALARM 1 / A	MODE (note n.2)	Normal, 1-OF-3, 3-OF-3, DERIV, UNBAL	NORMAL
	TYPE (note n.3)	MAX, MIN	MAX
	MEAS (note n.4)	Controlled measure. See table n.1 for the register selection	344
	THRE (note n.4)	Threshold value	100000
ALARM 1 / B	HYST	1...100 (%)	5
	DELAY	1...99 (seconds)	5
	AVG (note n.5)	1...99 (seconds)	1
	OUT (note n.6)	Normal, Hold, Pulse-L, Pulse-S	NORMAL
DIGITAL OUT 1	MODE	PULSE, ALARM, REMOTE	ALARM
	POLARITY	NO, NC	NO

In order that the output "DIGITAL OUT 1" gets excited and remains such during all the alarm (latching): when the Average Active Power (MEAS 344) falls below the value of 90 kW, hysteresis 5% and delay of 5 seconds, set the parameters as in the table below:

ALARM 2 / A	MODE (note n.2)	Normal, 1-OF-3, 3-OF-3, DERIV, UNBAL	NORMAL
	TYPE (note n.3)	MAX, MIN	MIN
	MEAS (note n.4)	Controlled measure. See table n.1 for the register selection	344
	THRE (note n.4)	Threshold value	90000
ALARM 2 / B	HYST	1...100 (%)	5
	DELAY	1...99 (seconds)	5
	AVG (note n.5)	1...99 (seconds)	1
	OUT (note n.6)	Normal, Hold, Pulse-L, Pulse-S	NORMAL
DIGITAL OUT 2	MODE	PULSE, ALARM, REMOTE	ALARM
	POLARITY	NO, NC	NO

VOLTAGE AND CURRENT CONNECTION

Voltage connection - Use cables with max cross-section of 2,5 mm² if flexible 4 mm² if rigid and connect them to the terminals marked voltage input on the instrument according to the applicable diagrams that follow.

Connessioni amperometriche

Use SHUNT with a suitable primary range and a 60 o 100 mV secondary. Connect the SHUNT to terminals signed with I1 (S1 e S2) (current input) as in the diagram.

SHUNT CONNECTED BEFORE

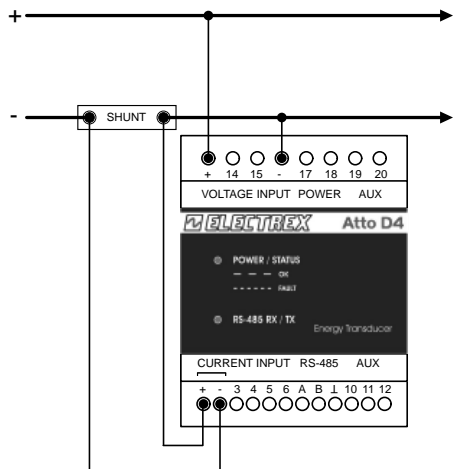

SHUNT CONNECTED AFTER

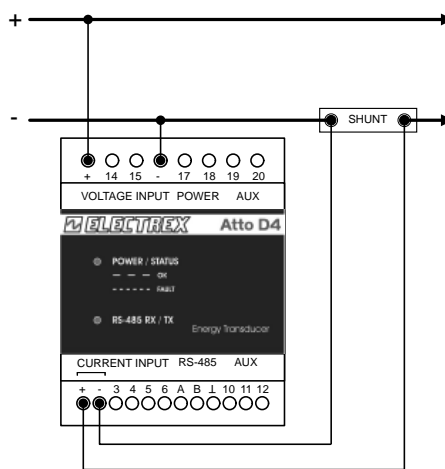

POWER SUPPLY AND SERIAL LINE CONNECTION

The instrument is equipped with a separate power supply. The power supply terminals are number as 17 e 18. The max cross-section of the wires is of 2,5 mm² if flexible and 4 mm² if rigid.

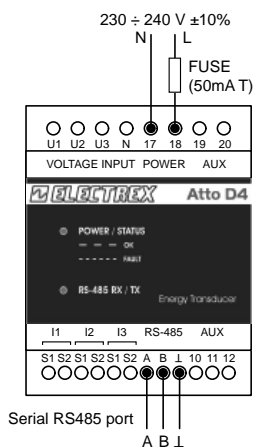

INPUT AND OUTPUT CONNECTION EXAMPLES

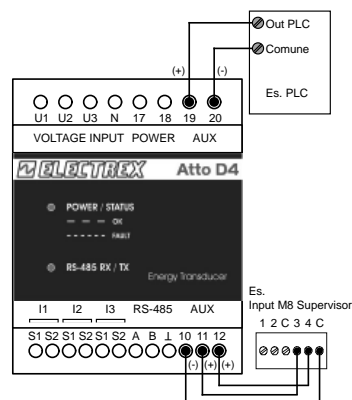

FROM:
 - TRANSDUCER WITH CONTACT CLEAN
 - GME
 - STATE ON-OFF
 - STATE ALARMS

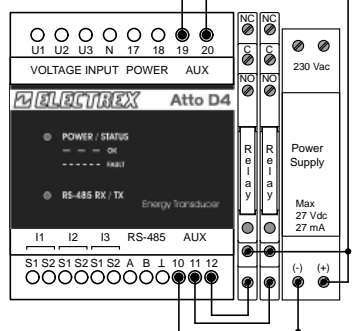

INPUT OUTPUT CONNECTIONS (ONLY FOR VERSION PFA7471-12)

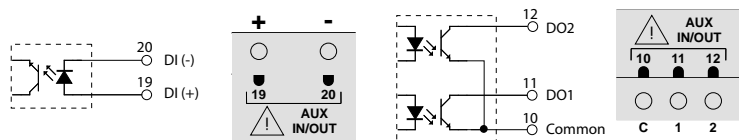

DIGITAL INPUTS	
Power supply voltage (external)	from 10 to 30 Vdc
Current absorbed :	from 2 to 10mA
Max. counting frequency:	10 or 100Hz
Note: for the gas counter, a galvanic insulated divider following ATEX normative, is needed.	

Digital optically insulated outputs, transistor based, (NPN) following standard DIN 43864.	
Max voltage applicable	27 Vdc
Max commutable current:	27mA